

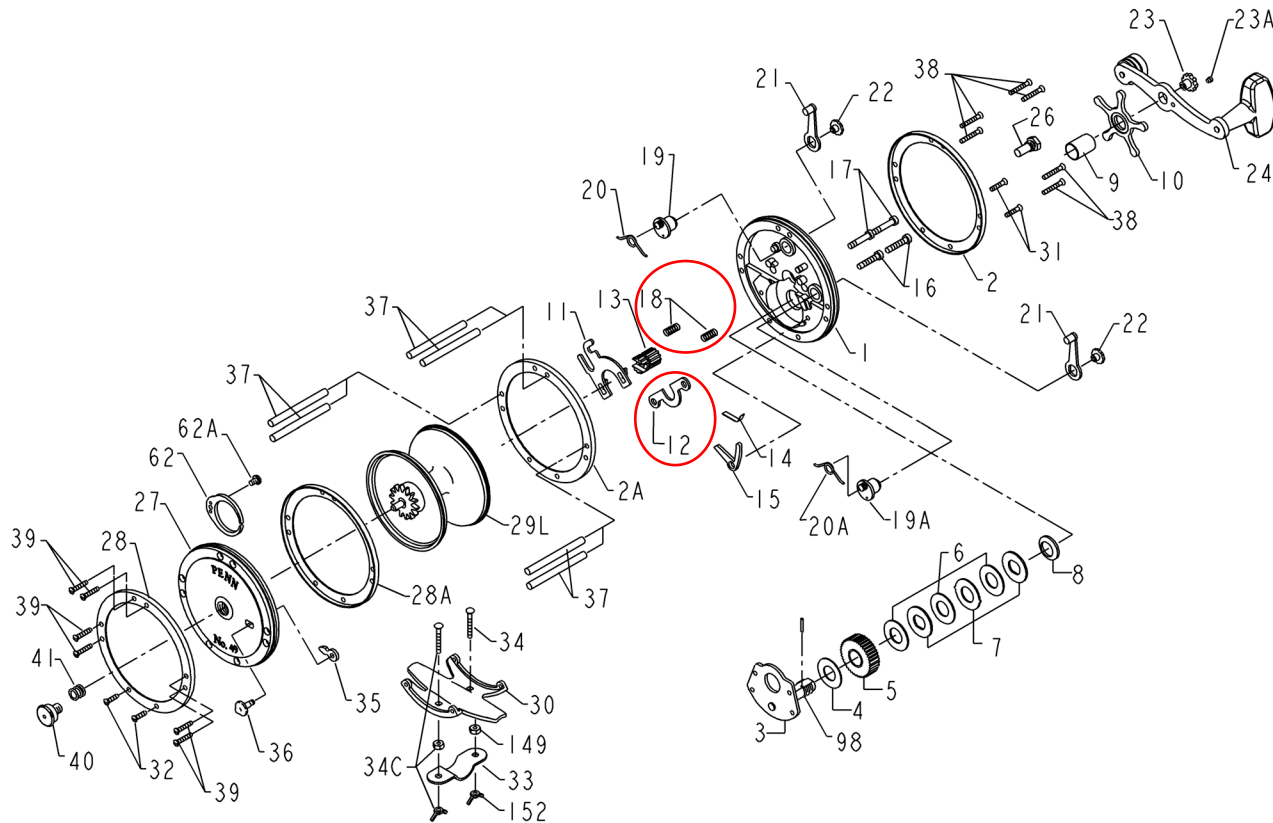

PARTS LIST FOR MODELS 49L AND 149L



KEY NO.	DESCRIPTION	MODEL 49L PART NO.	MODEL 149L PART NO.
1	Right Side Plate	001 049	001 149
2	Outer Ring	002 049OL	002 049OL
2A	Inner Ring	002 049I	002 049I
3	Bridge w/Sleeve	003 049	003 149
4	Fiber Washer	004 060	004 060
5	Main Gear	005 049	005 149
6	Drag Washer (3 req.)	006 049	006 060
7	Metal Washer Set	007C049	007C060
8	Tension Spring	008 060	008 060
9	Spacing Sleeve	009 060	009 060
10	Star Drag Wheel	010 049	010 049
11	Eccentric Jack	011 049	011 049
12	Pinion Yoke	012 060	012 113
13	Pinion	013 049	013 113
14	Dog Spring	014 049	014 049
15	Dog	015 049	015 149
16	Lower Bridge Screw (2 req.)	016 060CH	016 060CH
17	Upper Bridge Screw (2 req.)	017 060CH	017 060CH
18	Clutch Spring (2 req.)	018 060	018 060
19	Eccentric Cam	019 060	019 060
19A	Eccentric Cam	019 049	
20	Eccentric Spring	020 060L	020 060L
20A	Eccentric Spring	020 155	020 155
21	Eccentric Lever	021 049 (2 req.)	021 049 (1 req.)
22	Eccentric Screw	022 060CH (2 req.)	022 060CH (1 req.)
23	Handle Screw	023 060	023 060
23A	Handle Lock Screw	110 060	110 060
24	Handle	024 049	024 049
26	Right Side Bearing	026 060	026 060
27	L.S. Plate	027 049	027 149
28	Outer L.S. Ring	028 049O	028 049O
28A	Inner Ring	002 049I	002 049I
29L	Spool	029L 049	029L 049
30	Stand	030 049	030 149
31	R.S. Stand Screw	039 003	038 008
32	L.S. Stand Screw	039 003	038 008
33	Rod Clamp	039 003	038 008
34	Rod Clamp Screws (2 req.)	034 049	034 049
34C	Rod Clamp Screw w/Nuts	034C049	034C049
35	Click Tongue	035 060	035 060
36	Click Button	036 060CH	036 060CH
37	Post (6 req.)	037 049	037 049
38	L.S. Post Screw (3 req.)	039 009	039 006
39	R.S. Post Screw (3 req.)	039 009	039 006
40	Complete L.S. Bearing	040 060	040 060
41	L.S. Bearing Spring	041 060	041 060
62	Click Spring	062 309	062 309
62A	Click Spring Screw	063 209	063 209
98	Gear Sleeve	098 060	098 060
149	Hex Nut	149 200	149 200
152	Wing Nut	152 200	152 200